



DESIGNER PANELS
FOR ALL YOUR
ARCHITECTURAL
NEEDS



BUILDING STRONGER BONDS WITH COMMITMENT TO INNOVATION

In over 19+ years, EUROBOND has grown from strength to strength by delivering superior quality Metal Composite Panels with unmatched customer service. EUROBOND is a part of Euro Panel Products Limited.

Through the years, EUROBOND has been at the forefront of innovation and design. It has been our constant endeavour to create architectural landmarks across India. This undertaking is backed by our global reach that allows us to offer a wide range of panels. Providing innovative infrastructure solutions that align with modern India's aspiration is the core of our business.

We have a state-of-the-art manufacturing facility at Umbergaon that's equipped to produce 20000 sq mtrs every day. Our products also come with long warranties, enhancing the trust and confidence in our brand.

MISSION

To be India's best Metal Composite Panel manufacturer by consistently innovating. We aim to delight our customers with our products & services. Alongside, we are also striving to build an inclusive work culture adhering to the ethical values of EUROBOND and its stakeholders.

VISION

To raise the standards of quality in the construction industry across India and abroad. We aspire to be the global leaders in the Panel industry with a commitment to innovation and unmatched customer service.

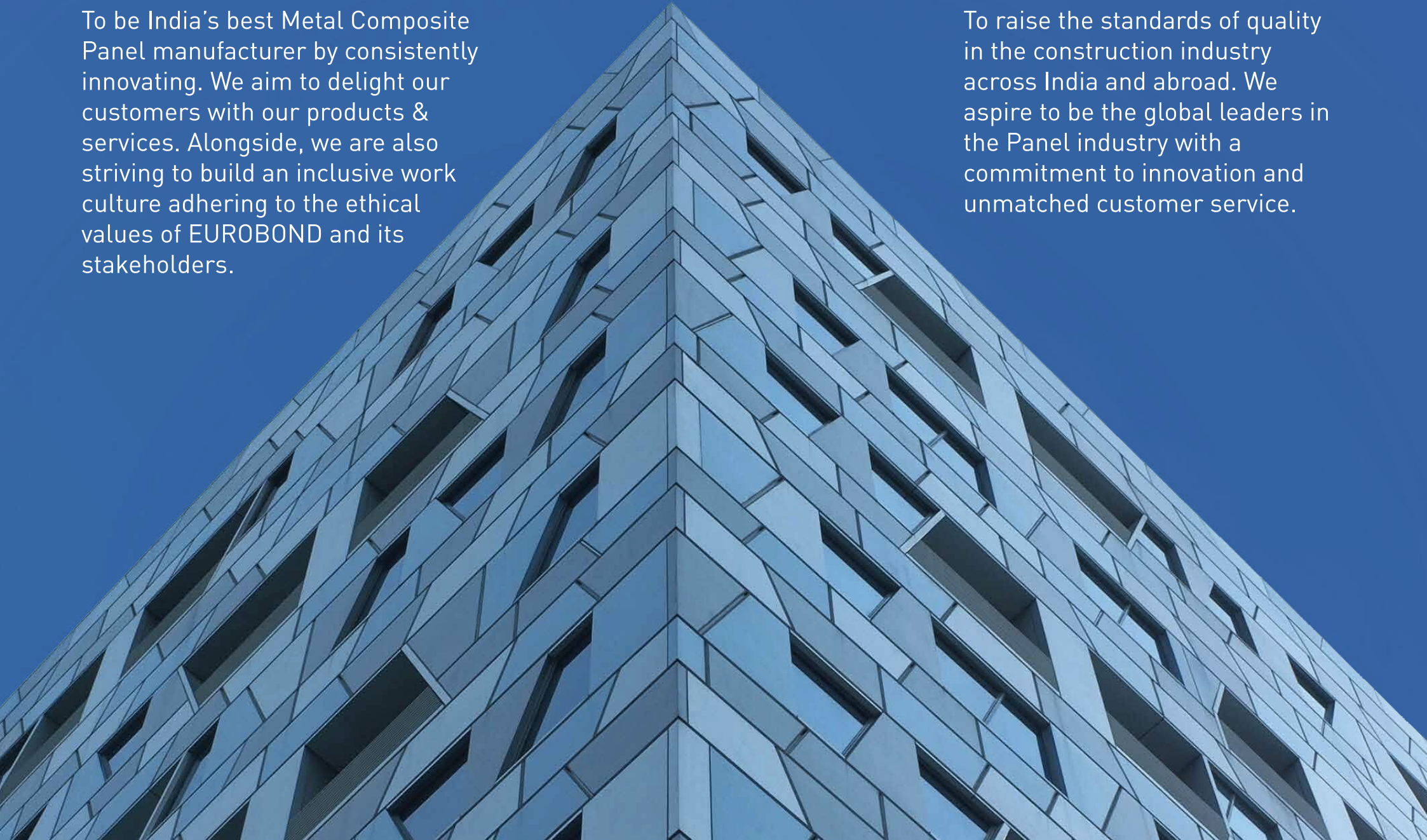

BUILDING STRONGER BONDS, BY INVESTING IN PEOPLE'S GROWTH

EUROBOND has always been one big family, of employees, distributors, dealers and customers. We've always believed in growing stronger, together. The team behind the dream EUROBOND has been the real strength that has empowered us to live up to our commitment, every single time.

We are thankful to the people who share our vision and have been helping EUROBOND achieve its mission, of being the best in the industry with innovation, strong work ethic and environmentally-friendly processes.



BUILDING STRONGER BONDS, WITH STATE-OF-THE-ART MANUFACTURING

To cater to the varied needs of our customers, we have set up a state-of-the-art manufacturing unit with 4 production lines that enable 24-hour production at Umbergaon. It is spread over an extensive 1.52 lac square feet with the installed capacity of producing 20,000 square meters of ACP per day. The manufacturing unit has been bestowed with TUV Certification for ISO 9001:2015 and FPC (Factory Production Certificate) from Exova Warringtonfire for Fire Retardant Class B and Class A2 production.

With a skilled workforce of 300+ people, highly precise world-class equipment and stringent focus on quality, we've managed to deliver the best-in-class quality to our clients.

At EUROBOND, we believe in the optimum use of resources and adhere to a minimal wastage policy. To support renewable green energy, we have installed solar panels that generate 500KW power per month. We've always followed Kaizen by constantly upgrading our work practices.



BUILDING STRONGER BONDS THAT PASS STRINGENT QUALITY TESTS

EUROBOND places much emphasis on process control to achieve strict quality controlled production at all times as per ISO 9001-2015 system. All the input raw materials and finished products are continuously checked and tested by advanced test equipment.

The laboratory tests include:

BOND STRENGTH TESTS

Climbing Drum Peel Test | T-Roller Peel Test | 180° Peel Test

GENERAL COATING TESTS

Colour Comparison | Dry Film (Coating) Thickness Test | Gloss Test

PAINT CURING TESTS

T-Bend Test | Pencil Hardness Test | Hammer Pin Ball (Solvent rub) Test |
Reverse Impact test

COATING ADHESION TEST

Cross Hatch Cut Test(Dry/Wet/Boiling)

BUILDING STRONGER BONDS, BY CELEBRATING UNIQUENESS

EUROBOND ACPs are intended for durability and exquisiteness. They are a unique combination of beauty and strength. These accommodate structural deflections, control wind-driven rain and air leakage, minimize the effects of solar radiation and provide maintenance-free, long-term performance.



SALIENT FEATURES

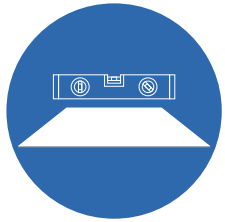

Superior Flatness



Light-weight



Paint Finish Consistency

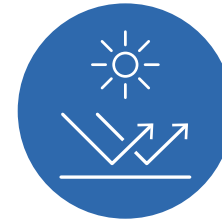

UV-resistant



Weather-proof



Available in
Fire Retardant



Impact-resistant

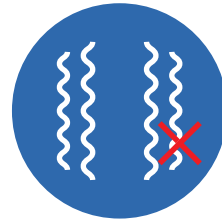

Vibration-resistant,
Dampening-resistant

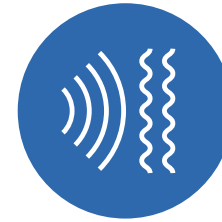

Sound and
Heat Insulation



Easy Installation
and Maintenance

PANEL COMPOSITION

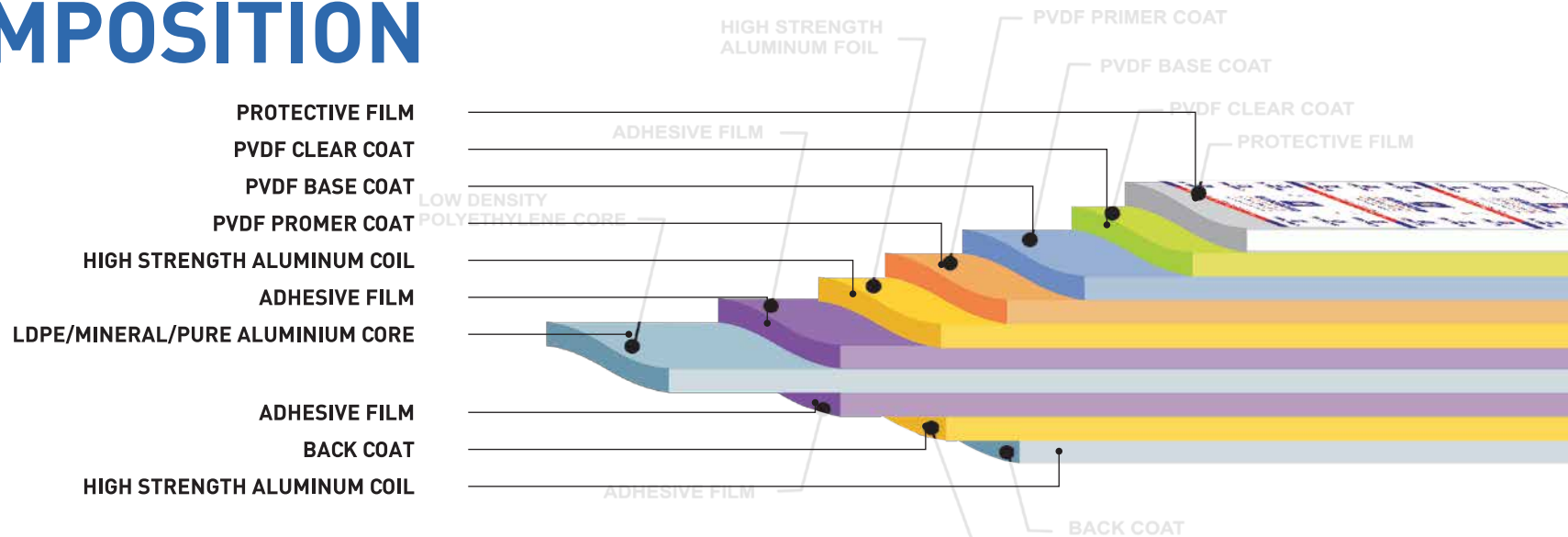



Ferrari World, Abu Dhabi
Colour : Ferrari Red

BUILDING STRONGER BONDS, TO MAXIMIZE CREATIVE POSSIBILITIES

EUROBOND has partnered with EURAMAX, Europe's leading coil manufacturer to bring you an exclusive range of ACPs with unmatched quality, unparalleled designs and exciting new colours and textures. This collaboration will give the impetus to our goal of transforming Indian spaces in style. Get ready to be spoilt for choice with access to a 10,000+ product range.

The exclusive access to a wide array of ACPs is backed by an assurance of superior quality conferred by high-grade coating finishes and 15 to 20 years warranty. EUROBOND is proud to be the only one to present the Indian markets with Euramax's 50 years of experience enriched with prestigious projects worldwide.

DISCOVER THE CHIC AND STYLISH EURAMAX COLLECTION





BUILDING STRONGER BONDS WITH ECO-FRIENDLY AHPL

It's time to move over HPL boards and embrace the new-age innovation in cladding, EUROBOND AHPL panels.

Aluminium HPL (AHPL) is all-weather friendly, making it perfect for a variety of interior and exterior applications including, Cladding, Canopy, Railing, Fencing, Doors, etc. AHPL is designed to be durable with gorgeous finish and textures.

A unique feature of AHPL is its Brown core colour, which resembles Coil's base colour. This makes it look elegant apart from the assured quality which AHPL offers and is also easy to install.

AHPL offers the same advantages as ordinary HPL while eliminating the challenges.

AHPL is made with excellent virgin quality material. What's more, it is a highly formable series and relatively 30-50% cheaper.

The icing on the cake is a 7 & 10 years warranty, which just adds to the trust and confidence in the brand.

INSTALLATION PROCESS

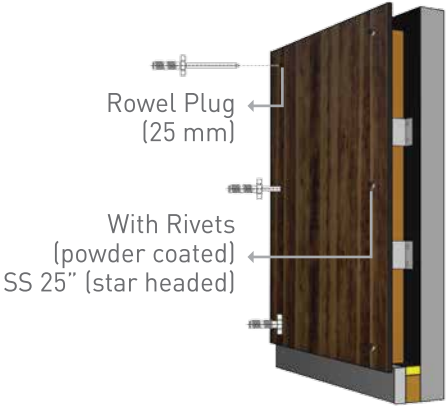
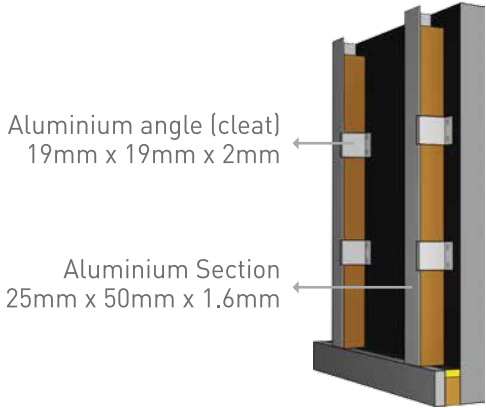
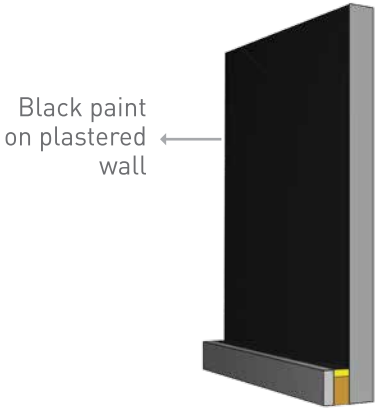

ALUMINIUM HPL (AHPL) FEATURES



Fully Recyclable



Borer, Fungi,
Termite Proof



Facilitates
LEED Certifications



No Swelling and
No Shrinkage



Rich Feel



Light-weight and
Easy-to- install



Available in
Fire Retardant



Zero Fumes

EXPERIENCE THE VERSATILITY OF AHPL

Because of its many distinctions, Architects and Designers find AHPL just right and recommend it for a variety of applications.

Versatility: As mentioned earlier, AHPL is an extremely versatile material that finds use in applications like vertical surfaces as well as horizontal ones. It has wide application in all forms of outdoor cladding.

Durability: Manufactured with state-of-the-art technology, AHPL is highly durable and since it requires very little or no maintenance, it is very widely used in hospitals, laboratories, hotels, restaurants, various institutions, as well as in offices. AHPL has overcome the shortcomings of wood and traditional HPL as it is manufactured using an aluminium coil with a 3 layer PDVF coating that is resistant to dust. All this, and it also comes with an extended warranty of 7 & 10 years.

Safety: AHPL has high thermal resistance, making it safe for use in commercial spaces, laboratories, hospitals, kitchens and similar spaces. It is also available in fire retardant grades as per request.

Maintenance-free: Easy-to-clean and maintain, AHPL is hard-wearing and not prone to cracks, scratches from heat or moisture.



BUILDING STRONGER BONDS, DESIGNED TO FIGHT FIRE

To raise the bar in innovation and set new standards of safety, we launched EUROBOND FR- the exclusive range of Fire-retardant panels.

For years, fire safety has been overlooked. Now's the time to take adequate measures and take fire safety to the next level.

Being the pioneers in the ACP industry, we understand our responsibility in maintaining public safety. Our ACPs emit no toxic smoke, facilitating safer escape routes.

The self-extinguishing behaviour property of FR Core slows down the spread of fire. It also considerably reduces the intensity of the flames.

EUROBOND FR panels can be processed and fabricated as any other EUROBOND ACPs. They are very tough and weatherproof and, above all, do not actively contribute to combustion.

APPLICATION: Residential buildings, public utility buildings, mega stadiums, museums, corporate headquarters and offices, malls and supermarkets, car showrooms, fuel filling stations and many more.

TESTED BY



CERTIFIED BY



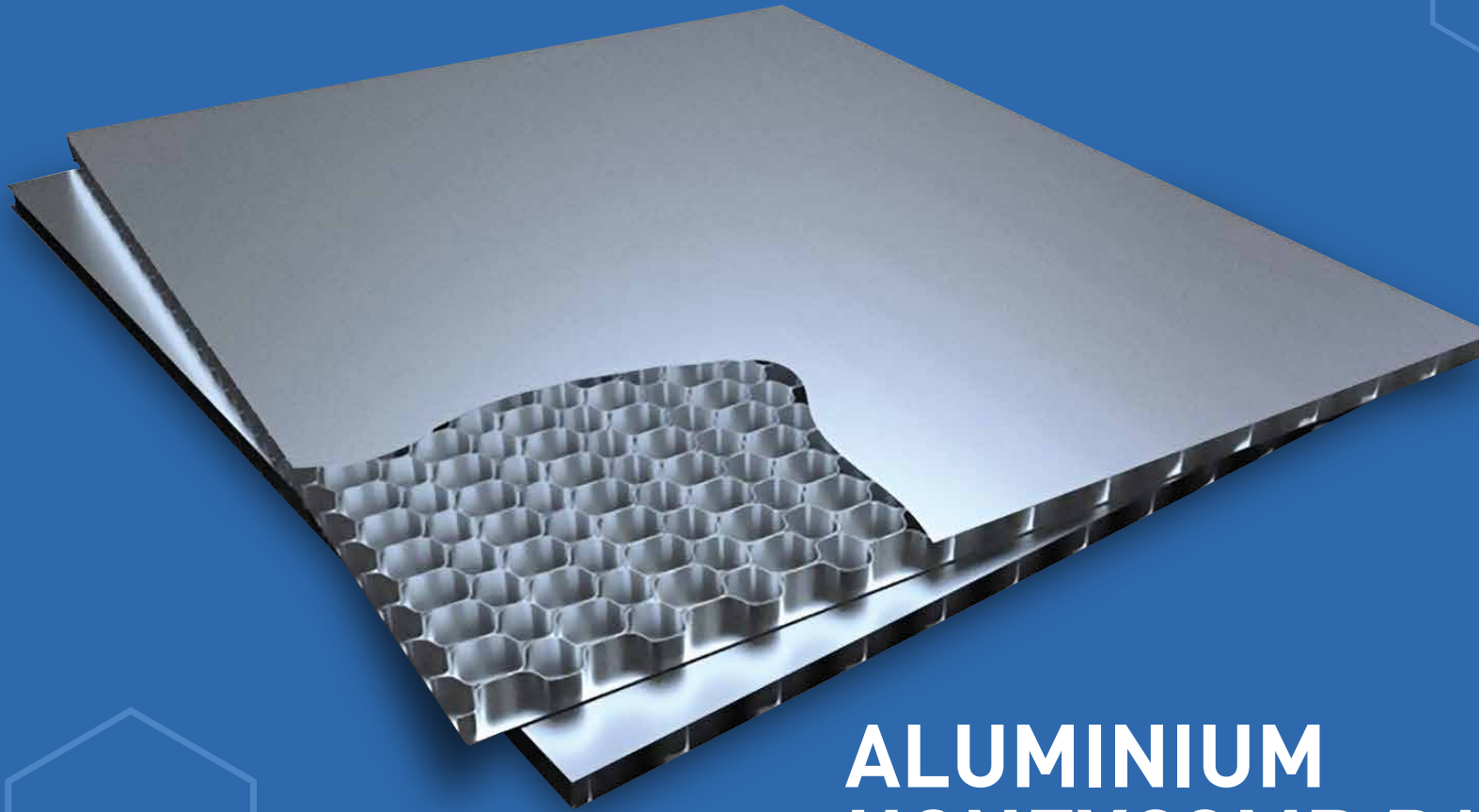

ALUMINIUM HONEYCOMB PANELS

Aluminium Honeycomb Panel is a sandwich panel with a honeycomb structure as its core, which is inspired by the natural hexagonal honeycomb. This unique structure makes the panel lightweight compared to other materials of the same volume. It also enhances stiffness and stability. The fact that these panels are completely recyclable makes them environment-friendly. And their fire-retardant properties make them the safer choice. With the best quality-control procedures which involve testing through advanced equipment, we can add to the trust that our customers place in us by offering a 15-year warranty on our Honeycomb Panels.

ALUMINIUM HONEYCOMB PANELS ADVANTAGES



Lightest Weight



Highest Strength

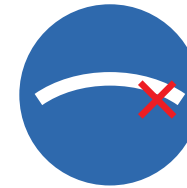

Superior flatness and
Exceptional stiffness



Eco-friendly



AA3003
Fully Recyclable



Sound Insulation



Easy Installation and
Maintainance



15 Years
Warranty



Fire Retardant
Class A2+

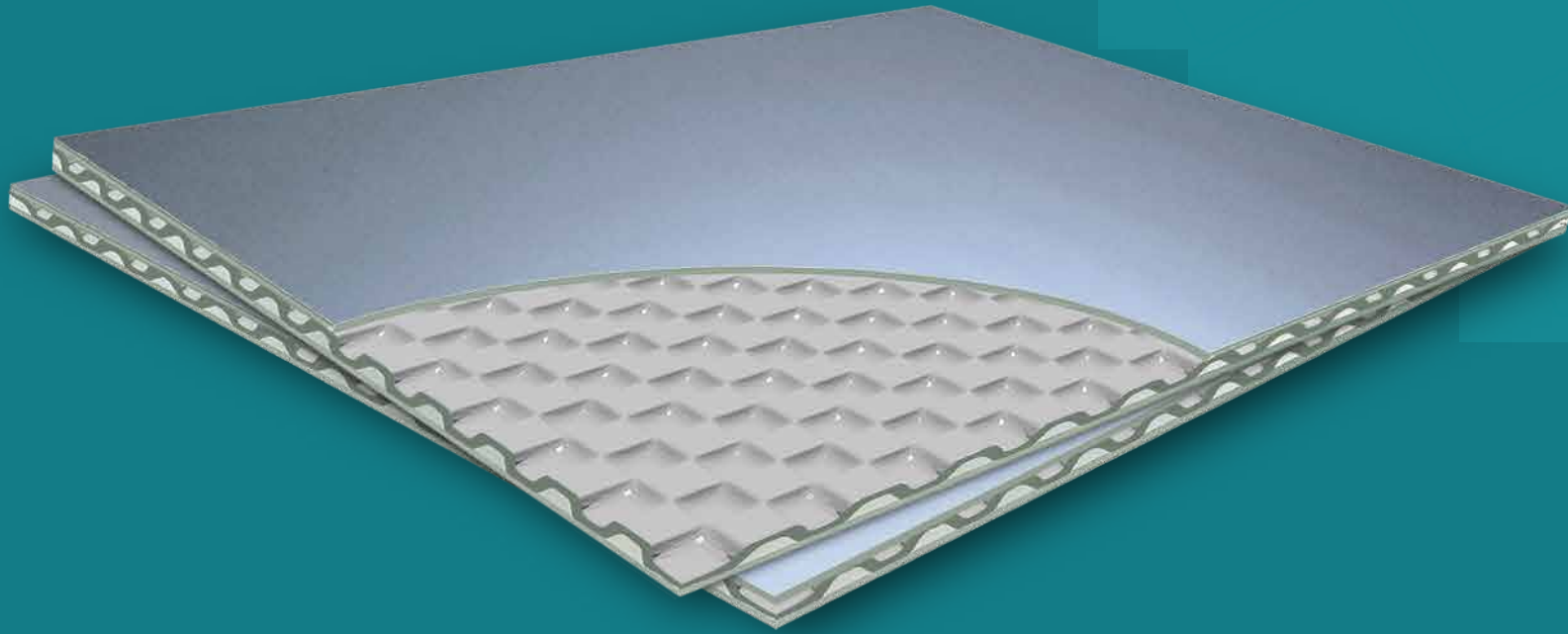

ALUMINIUM CORE COMPOSITE PANEL (ACCP)

What sets EUROBOND Aluminium Core Composite Panel (ACCP) apart from the rest is the innovation in the core technology, replacing combustible LDPE core with non-combustible Pure Aluminium Core. EUROBOND ACCP, along with A2 class fire retardance, offers the best strength to weight ratio among the three Classes. These sheets are formable, construction friendly and are also completely recyclable making them an eco-friendly option. These sheets are incombustible and very light in weight, leading to low installation costs and reducing load-bearing on the structure, aiding more and more applications in high rise buildings and constructions. EUROBOND ACCP sheets confirm as per EN 13501-1 as Class A2 - s1 d0.



A2 ACP

EUROBOND A2 ACP sheets are composed of a minimum of 90% mineral core sandwiched between two skins of aluminium alloy 3003/5005. The FR mineral core of EUROBOND A2 ACP is made of MDH and ATH Halogen-Free (HF) compounds, meaning they emit non-toxic harmless vapour upon forced burning, exhibit best flame self-extinguishing behaviour and are active smoke suppressants. These sheets don't contribute to the spread of fire at all in the event of a fire accident. EUROBOND FR A2 sheets confirm as per EN 13501-1 as Class A2 - s1 d0 rating and they have been tested and certified by Exova Warringtonfire, UK.

FR PLUS

EUROBOND FR Plus (Class B) Aluminium Composite Panels secure your buildings with superior performance and fire retardance on an economical budget. The FR core material contains 70% advanced mineral compounds which restrain flammability, flame propagation and smoke generation. The front skin being PVDF/FEVE coated provides excellent colour retention, gloss retention, UV stability, weathering resistance and pollution resistance for more than a decade with negligible periodic maintenance. EUROBOND FR PLUS sheets confirm as per EN 13501-1 as Class B - s1 d0 rating, and they have been tested and certified by Exova Warringtonfire, UK. EUROBOND FR Plus has a 3 Hour Fire rating for ASTM E 119, and it has been tested by Thomas Bell Wright, Dubai.





BUILDING STRONGER BONDS WITH PANELS IN 300 DESIGNS ACROSS 16 PRODUCT RANGE

We integrate inventiveness with superior quality to offer you a wide portfolio of ACPs that truly complement your architectural ambitions. With EUROBOND, you'll never run out of options in colour, design or texture.

METALLIC
SERIES

SOLID
SERIES

**HIGH
GLOSS**
SERIES

SPARKLE
SERIES

MIRROR
SERIES

WOODEN
SERIES

**WOODEN
TEXTURES**
SERIES

STONE
SERIES

MARBLE
SERIES

BRUSH
SERIES

SPECTRA
SERIES

HPL
SERIES

**TIMELESS
DESIGNS**
SERIES

**AUTHENTIC
TEXTURES**
SERIES

**GLAMOUROUS
JEWELS**
SERIES

**ZINC
REINVENTED**
SERIES

BOND THAT SIGNIFIES STRENGTH

When it comes to class and strength, EUROBOND is a name to count on. Our ACP and FR panels are made of three layers - non-toxic LDPE/Mineral/Pure Aluminium core inserted in-between two layers of Aluminium. This sandwich setup allows excellent mechanical performance at minimal weight. The panel then goes through an extensive coating process with Double Coat Double Bake process. The protective film protects the panel while cutting, transiting, grooving and folding, from mechanical damage and contamination of the surface. After finishing the installation, the protective film is taken off to make visible its true surface.



SPECIFICATION

Aluminium Panel Sheet Thickness: 1 mm to 6 mm

Core Thickness: 2.50 mm to 0.50 mm

Aluminium Foil Thickness: 0.04 mm to 1 mm

Width: 1220 mm, 1570 mm (maximum)

Length: 1500 mm to 6100 mm

Material: Alloy 3303

AA 3003 is a high strength alloy with good cold formability and excellent resistance to atmospheric corrosion. It has better mechanical properties, proven by its values of yield strength, ultimate strength, shear strength, modulus of elasticity, and shear modulus. This adds high strength and durability to the Panel.

Coating: PVDF Coating

PVDF coating makes our Panels weatherproof, UV resistant, waterproof, scratch-resistant and dustproof. It also makes the panels easy to maintain as they would only require twice-a-year cleaning with mild soap and water to restore them to their original glory.

APPLICATION CHART GRADE	TOTAL THICKNESS	FRONT COIL THICKNESS	LDPE CORE THICKNESS	BACK CORE THICKNESS	COATING	APPLICATION AREA
4 mm Platinum (4PL)	4 mm	0.50	3.00	0.50	PVDF	EXTERIOR
4 mm Titanium (4TI)	4 mm	0.25	3.50	0.25	PVDF	EXTERIOR
3 mm Ruby (3RB)	3 mm	0.25	2.50	0.25	PVDF	EXTERIOR
3 mm Gold (3GL)	3 mm	0.18	2.64	0.18	PE	INTERIOR
3 mm Silver (3SL)	3 mm	0.10	2.80	0.10	PE	INTERIOR

Special thickness and length available on request

BONDS THAT ARE CERTIFIED

TUV ISO 9001:2015 Certification



Exova Warringtonfire Certification:
EN 13501-1: 2018 Class A2



Exova Warringtonfire Certification:
EN 13501: 2018 Class B

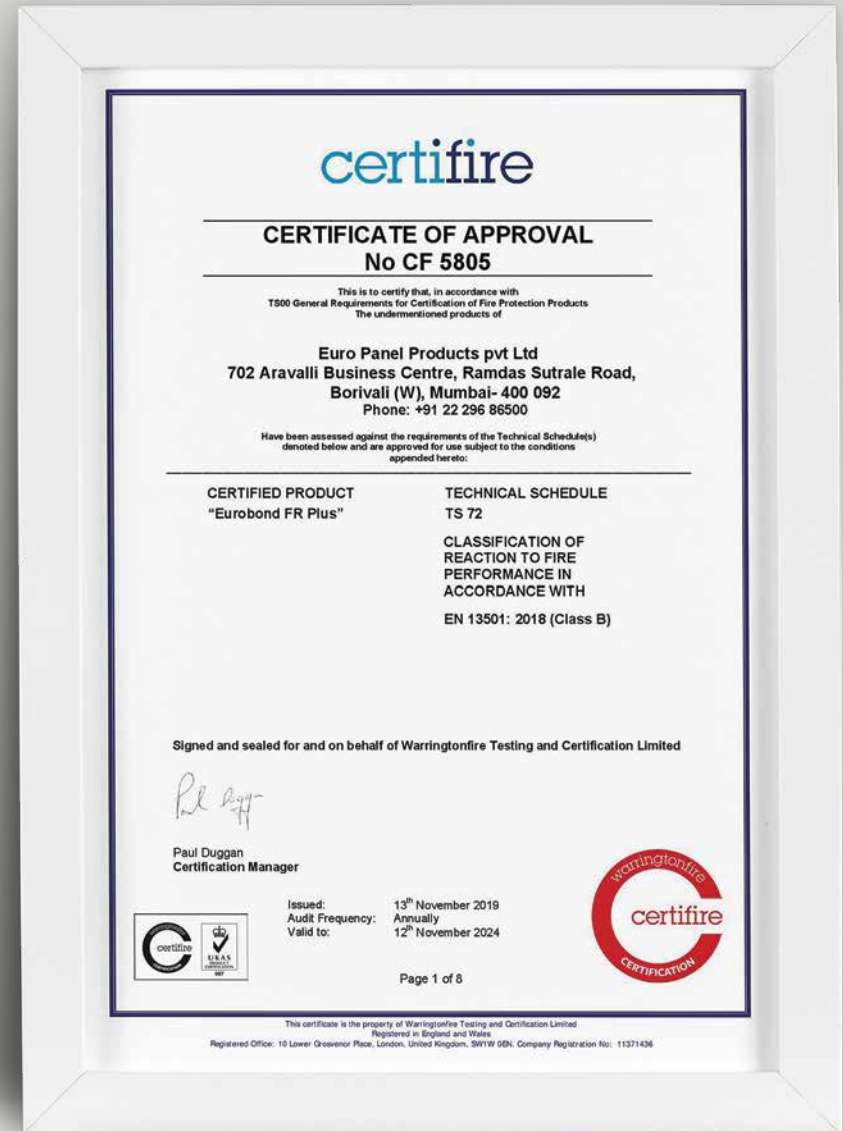

PROJECTS THAT MAKE US PROUD

Chetak Park - Nadiad

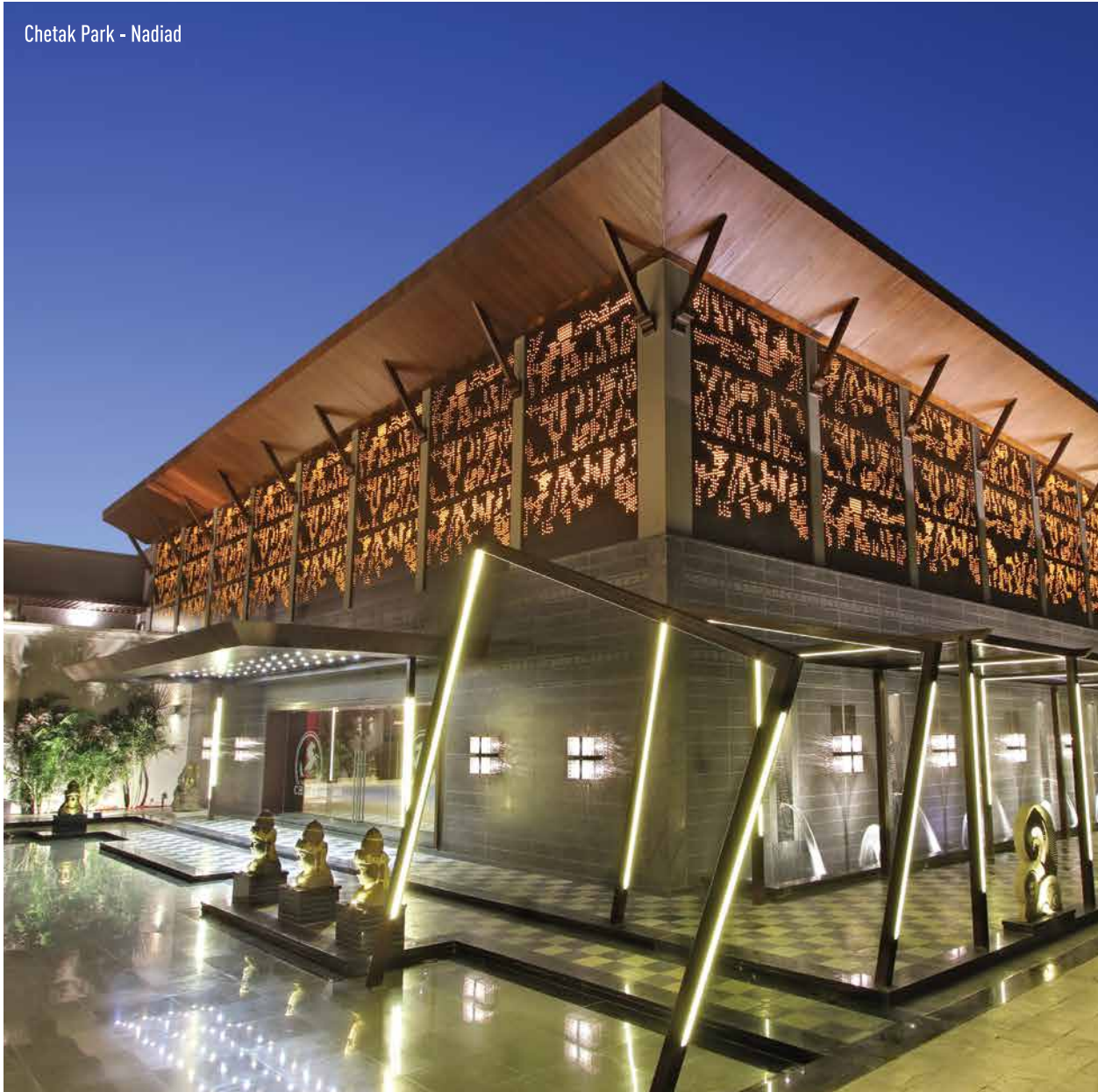

Velocity Business Center - Surat

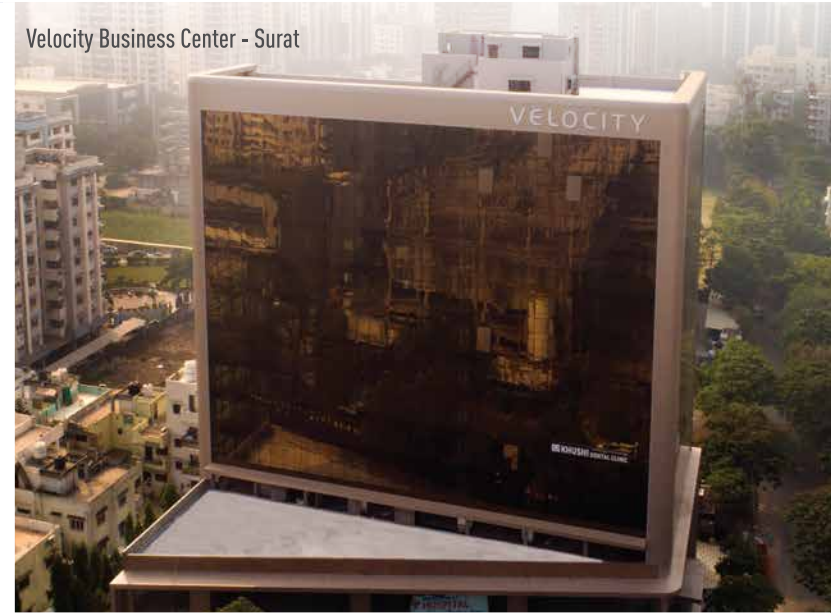

Millenium Tower - Surat



The Fern Hotel- Udaipur (Rajasthan)

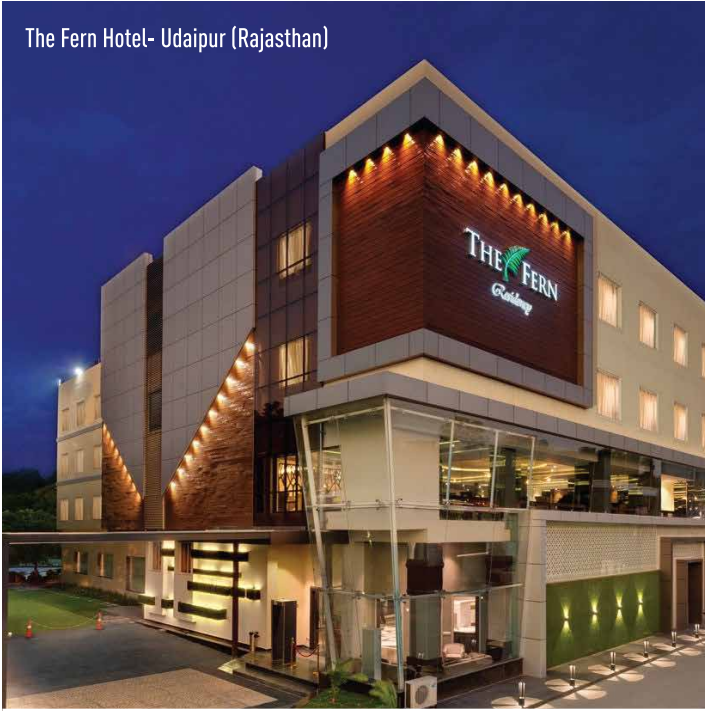

Renault - Hyderabad



Sapthagiri - Telangana



Adani - Ahmedabad



Maruti Suzuki - Indore (MP)



Shivalik Avenue - Surat



Mangalore Refinery and Petrochemicals Limited-Mangalore

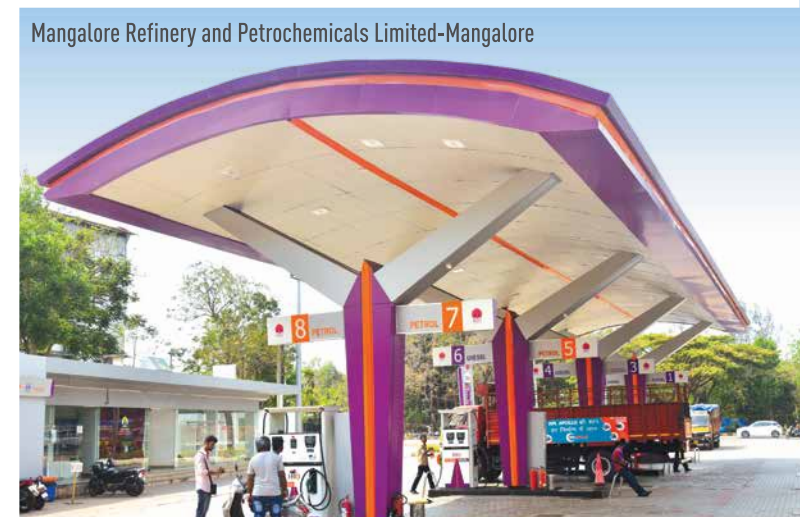

G Convention Centre - Telangana



Tirumala Gardens - Telangana



Sai Ashish Centre - Surat



SOME OF OUR ESTEEMED CLIENTELE

TRANSPORT



AUTOMOBILE



METRO



BANKING



GOVERNMENT SECTOR



PETROLEUM



SOME OF OUR ESTEEMED CLIENTELE

PHARMA/HOSPITALS



CORPORATE



CONSTRUCTION



RETAIL

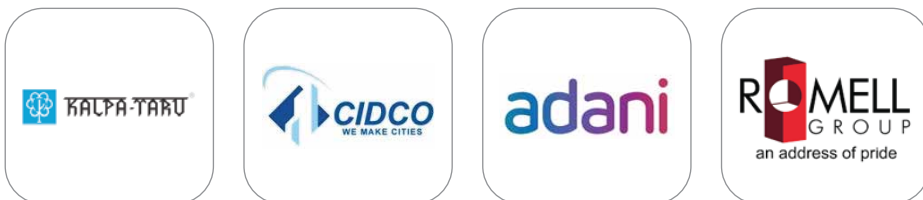

AND MANY MORE



EURO PANEL PRODUCTS LIMITED

(Formerly known as Euro Panel Products Pvt. Ltd.)

Regd. Off.: 702, Aravali Business Centre, Ramdas Sutrale Road, Borivali (West), Mumbai - 400 092
T: +91-22-29686500, +91-7666625999 • E: sales@eurobondacp.com • W: www.eurobondacp.com

Mfg. Unit: Survey No. 124/4, Manekpur, Sanjan, Khattalwada, Taluka - Umbergaon, Dist. Valsad, Gujarat - 396 120



FR Range Tested by



Follow us on:

